

RF (Version 1.0 Edit 167) for layout version 15

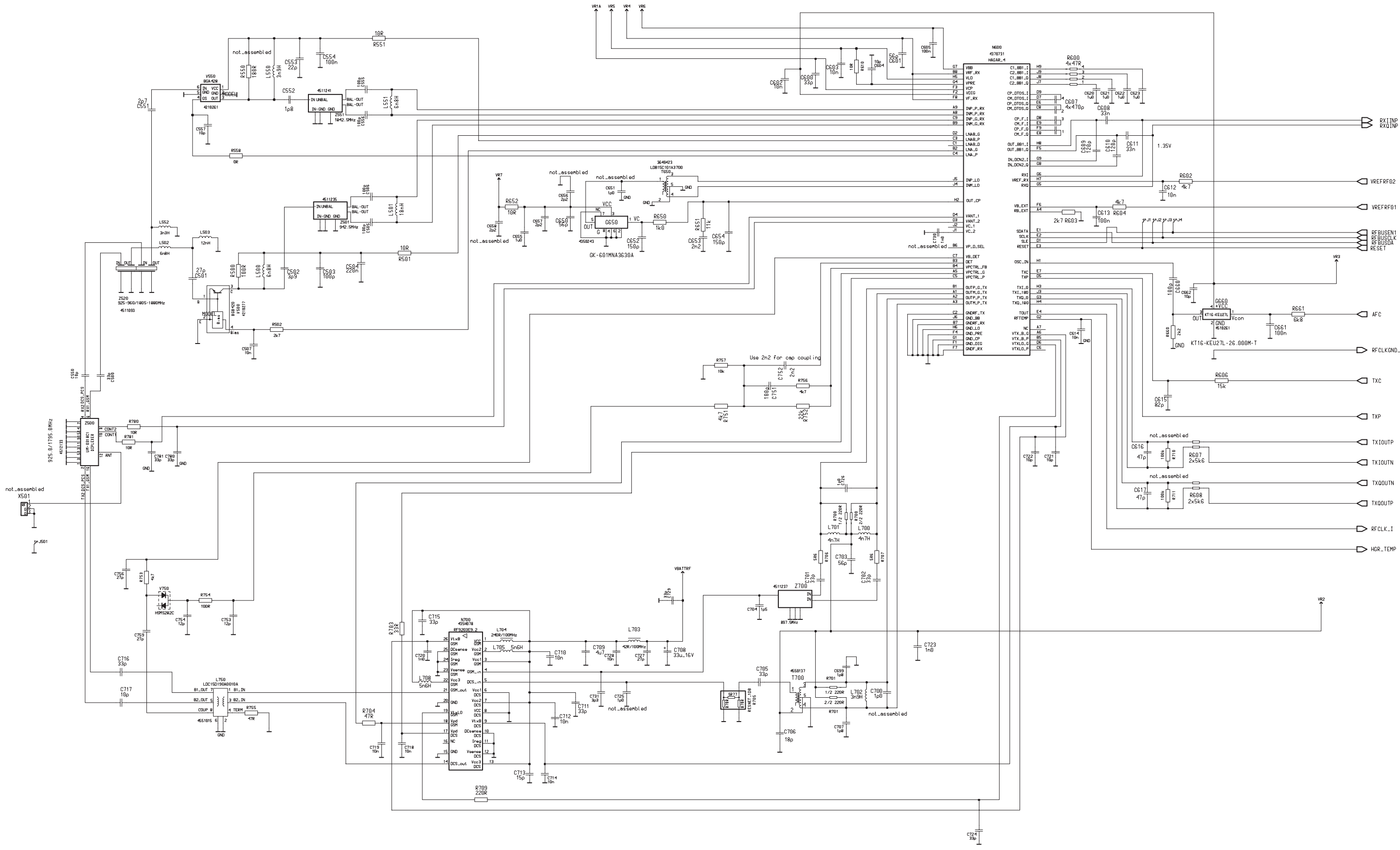

BB Connections (Version 0.0 Edit 96) for layout version 15

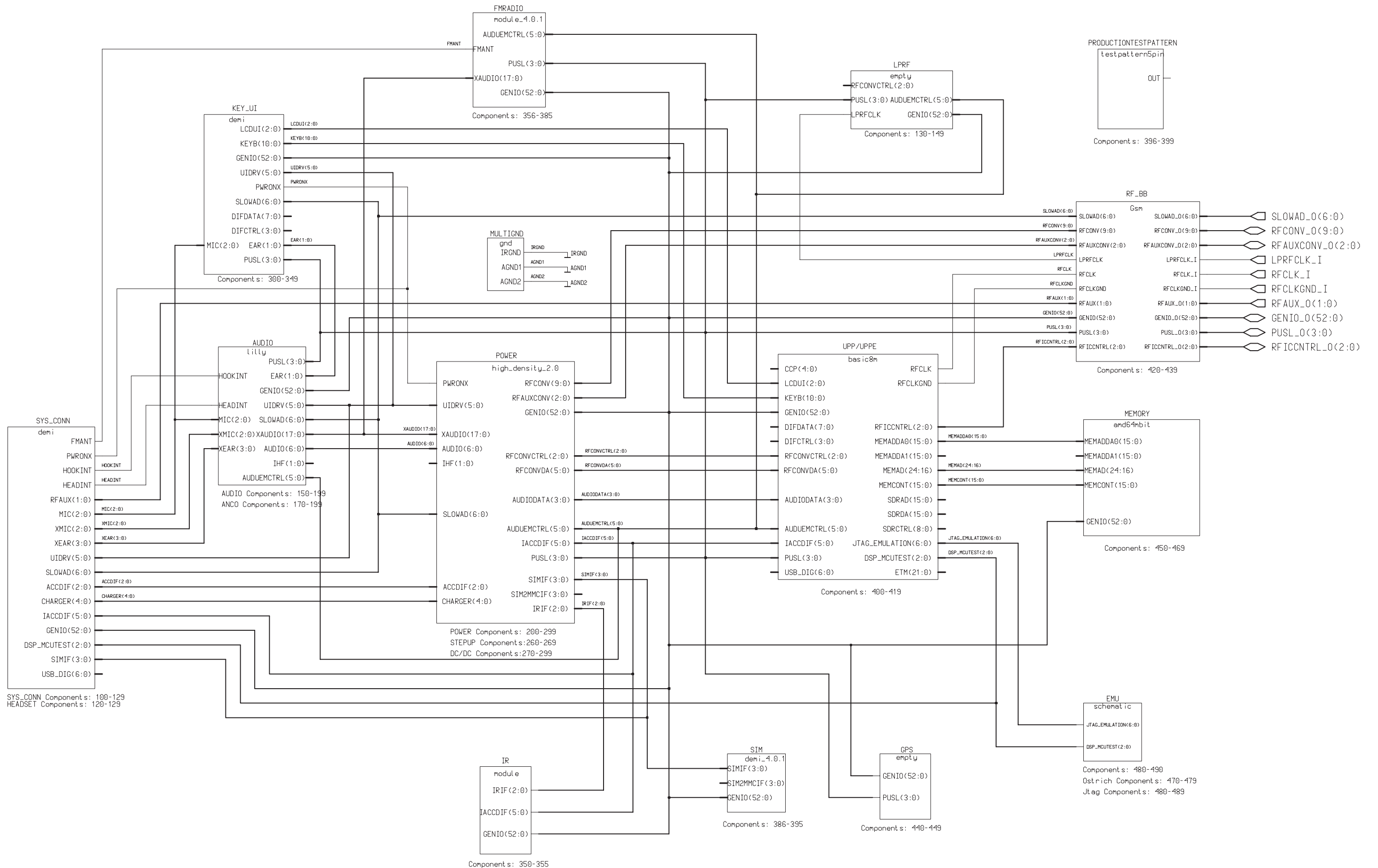

System Connector (Version 1.3 Edit 156) for layout version 15

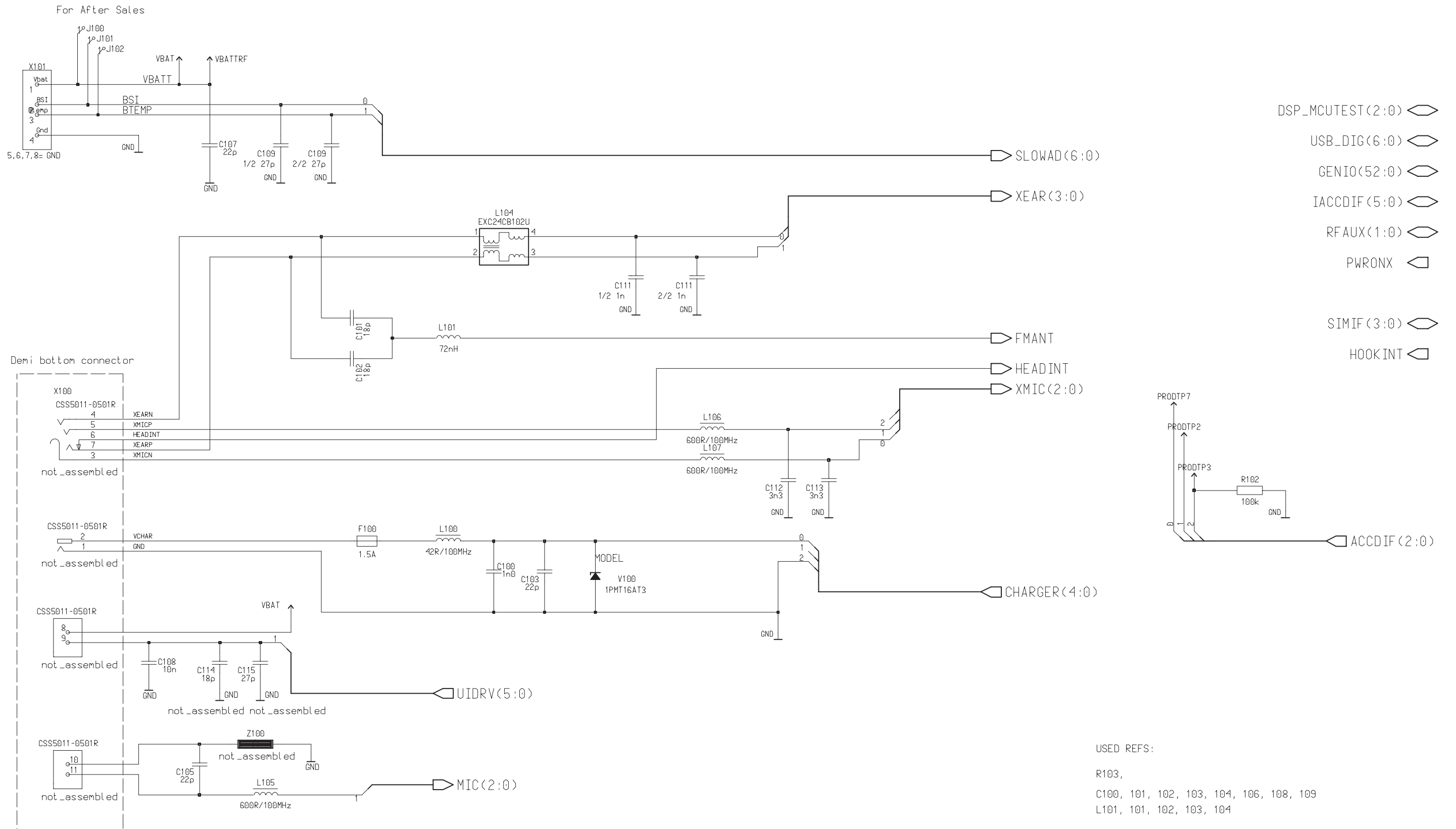

- DSP_MCUTEST(2:0)
- USB_DIG(6:0)
- GENIO(52:0)
- IACCDIF(5:0)
- RFAUX(1:0)
- PWRONX
- SIMIF(3:0)
- HOOK INT

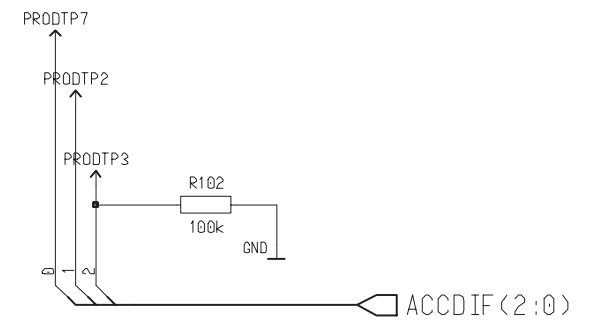

Audio Interface (Version 1.3 Edit 15) for layout version 15

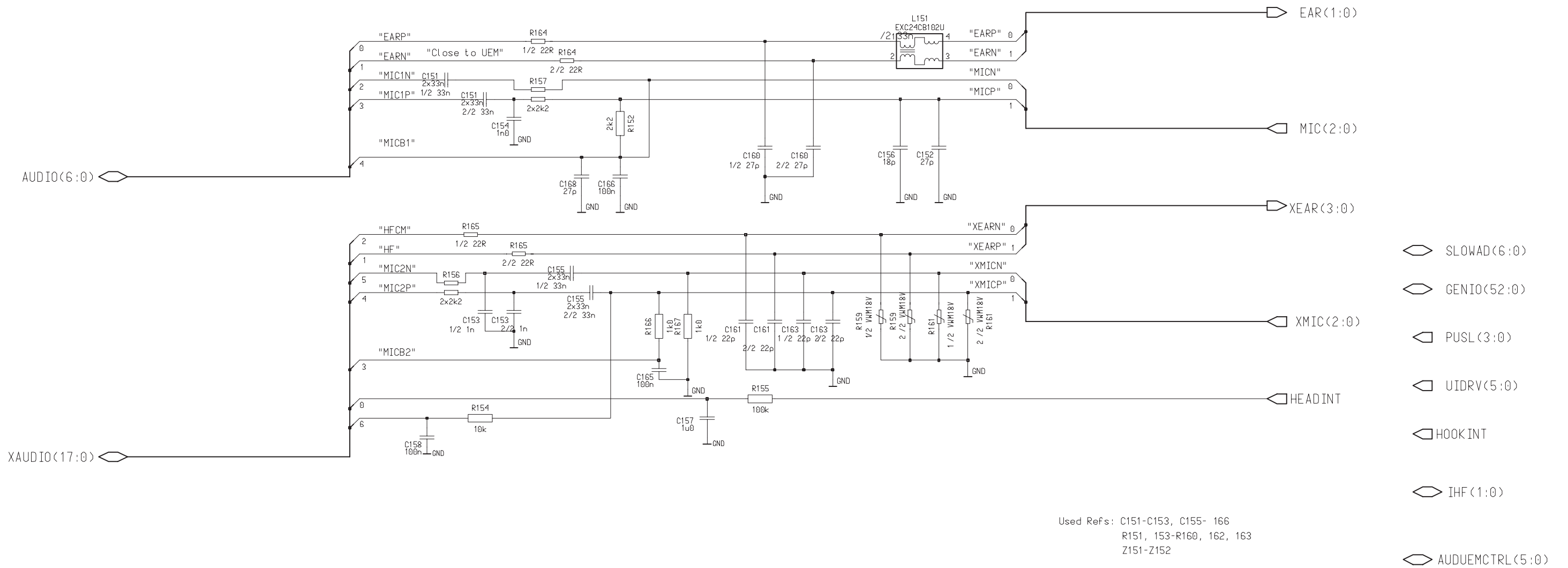

UEM of BB (Version 2.0 Edit 164) for layout version 15

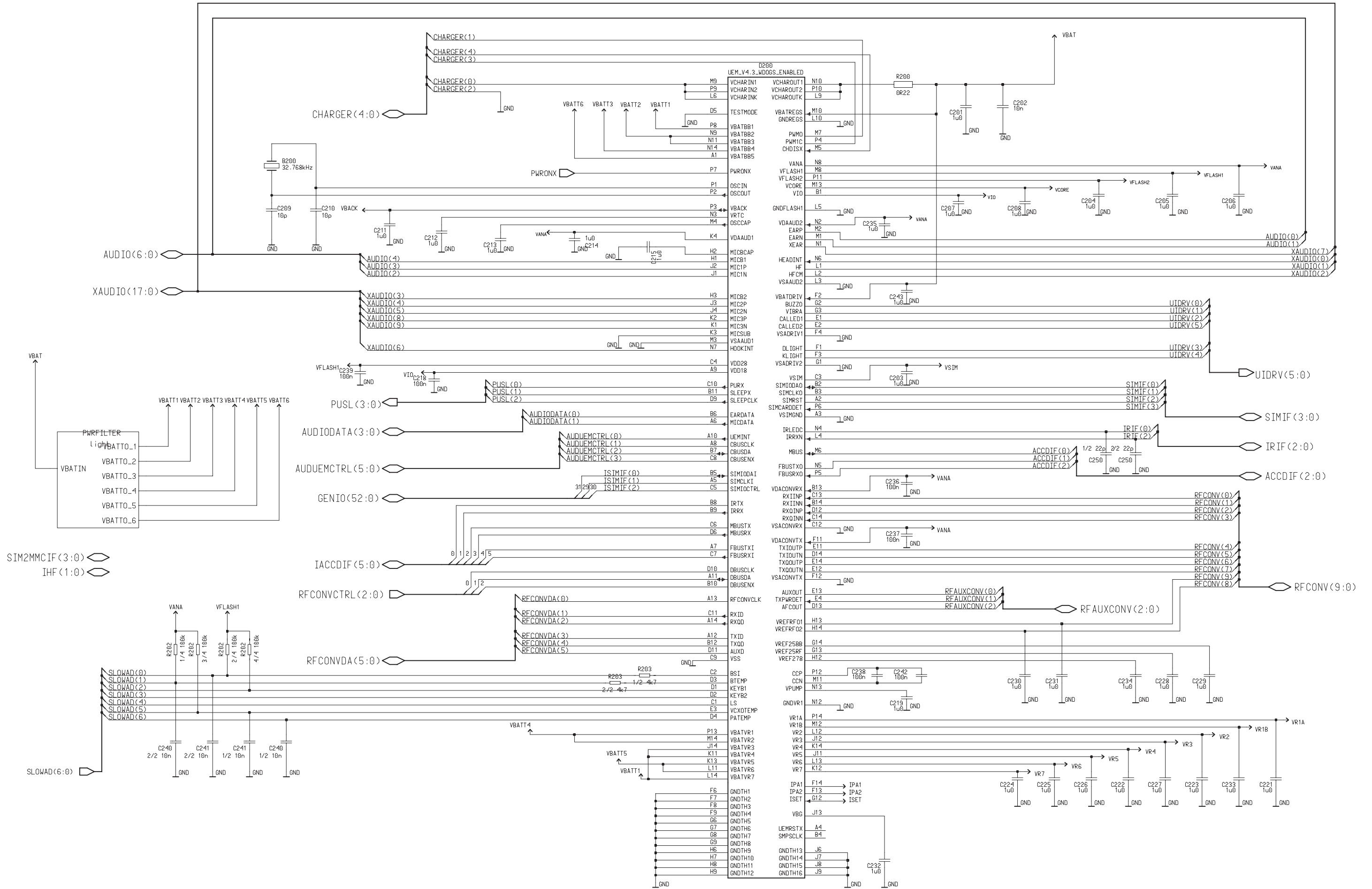

Light Filtering (Version 2.0 Edit 34) for layout version 15

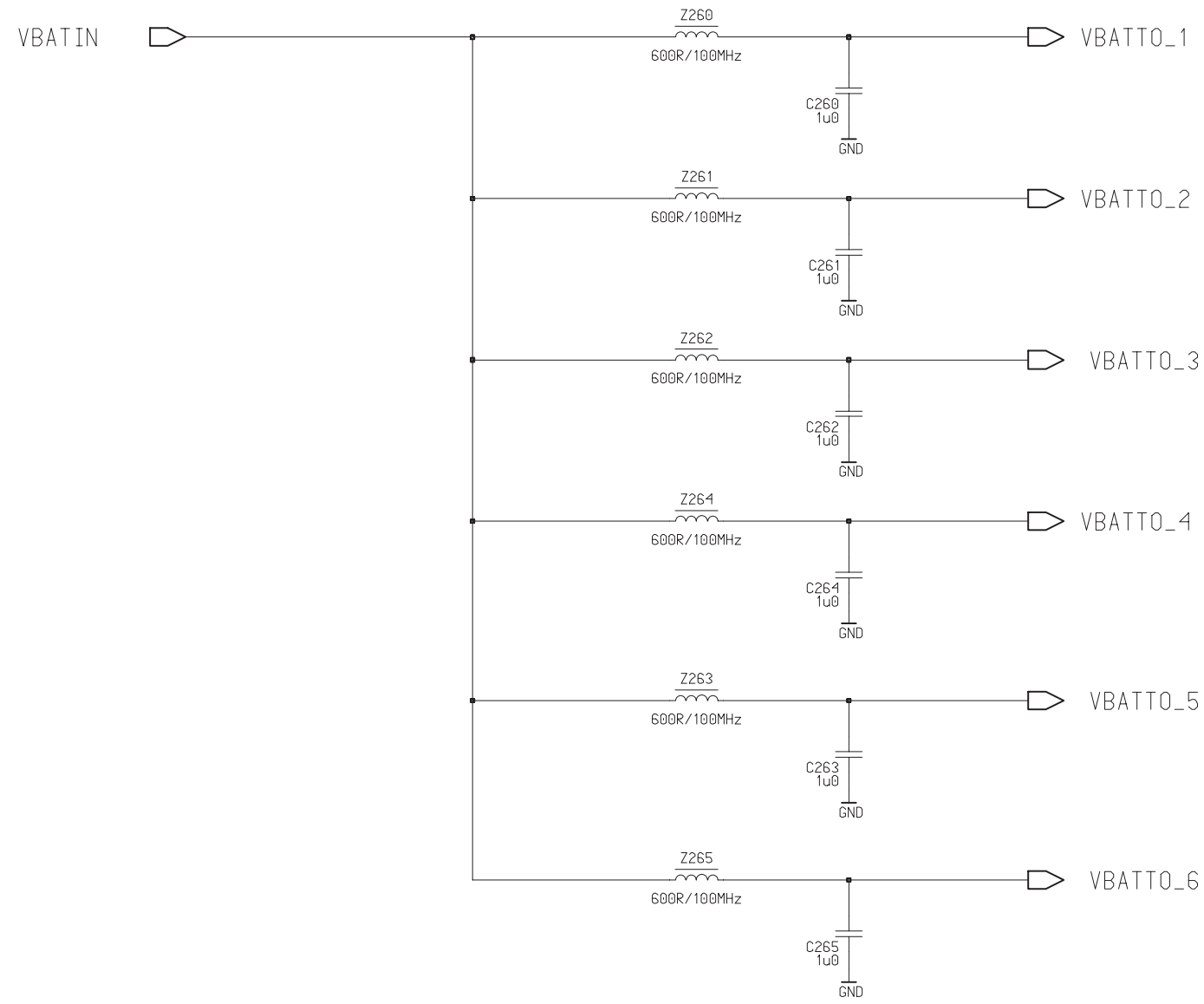

Display and Keyboard Interface (Version 1.3 Edit 201) for layout version 15

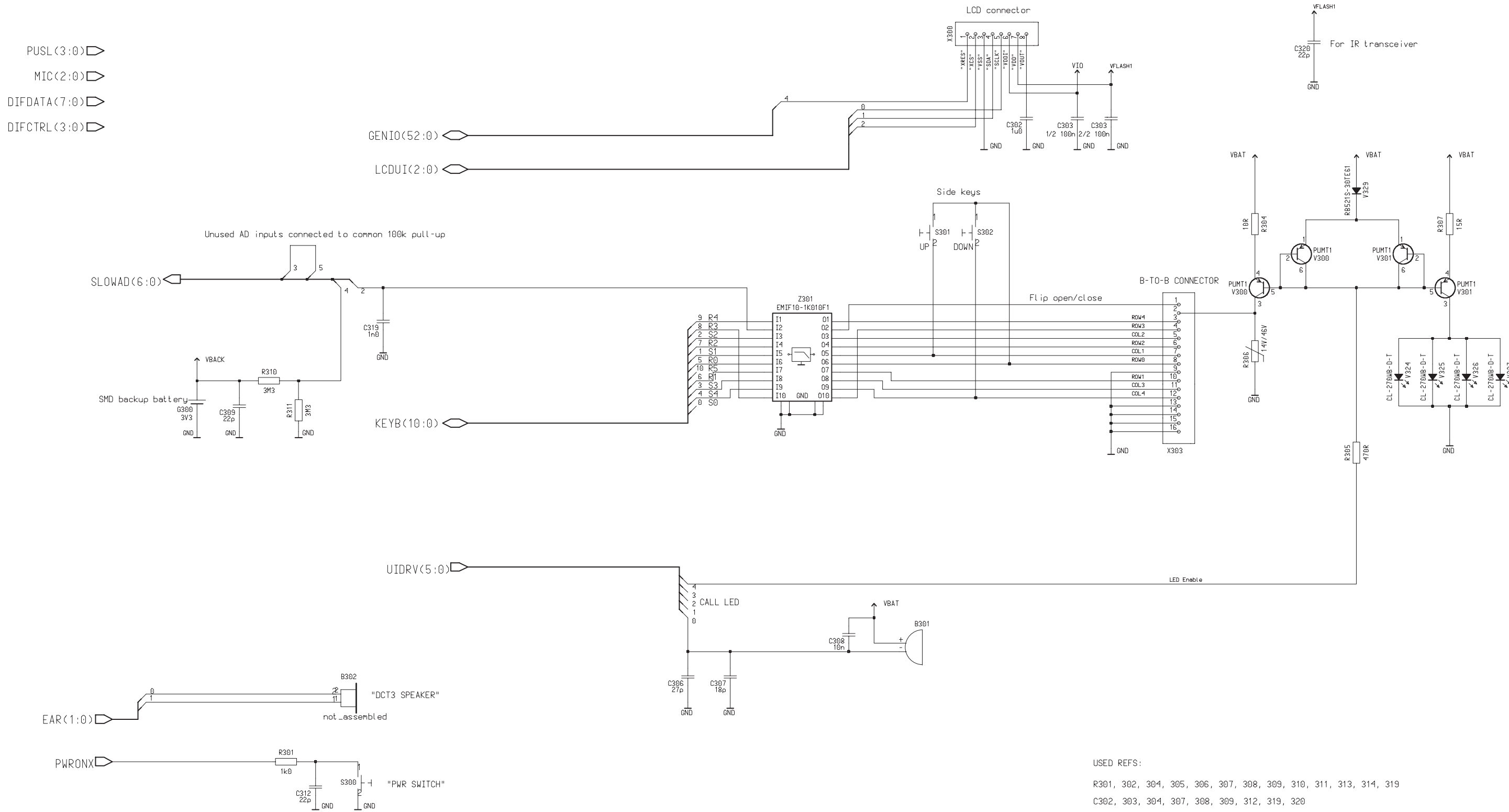

USED REFS:
R301, 302, 304, 305, 306, 307, 308, 309, 310, 311, 313, 314, 319
C302, 303, 304, 307, 308, 309, 312, 319, 320

Infrared Module (Version 2.0 Edit 37) for layout version 15

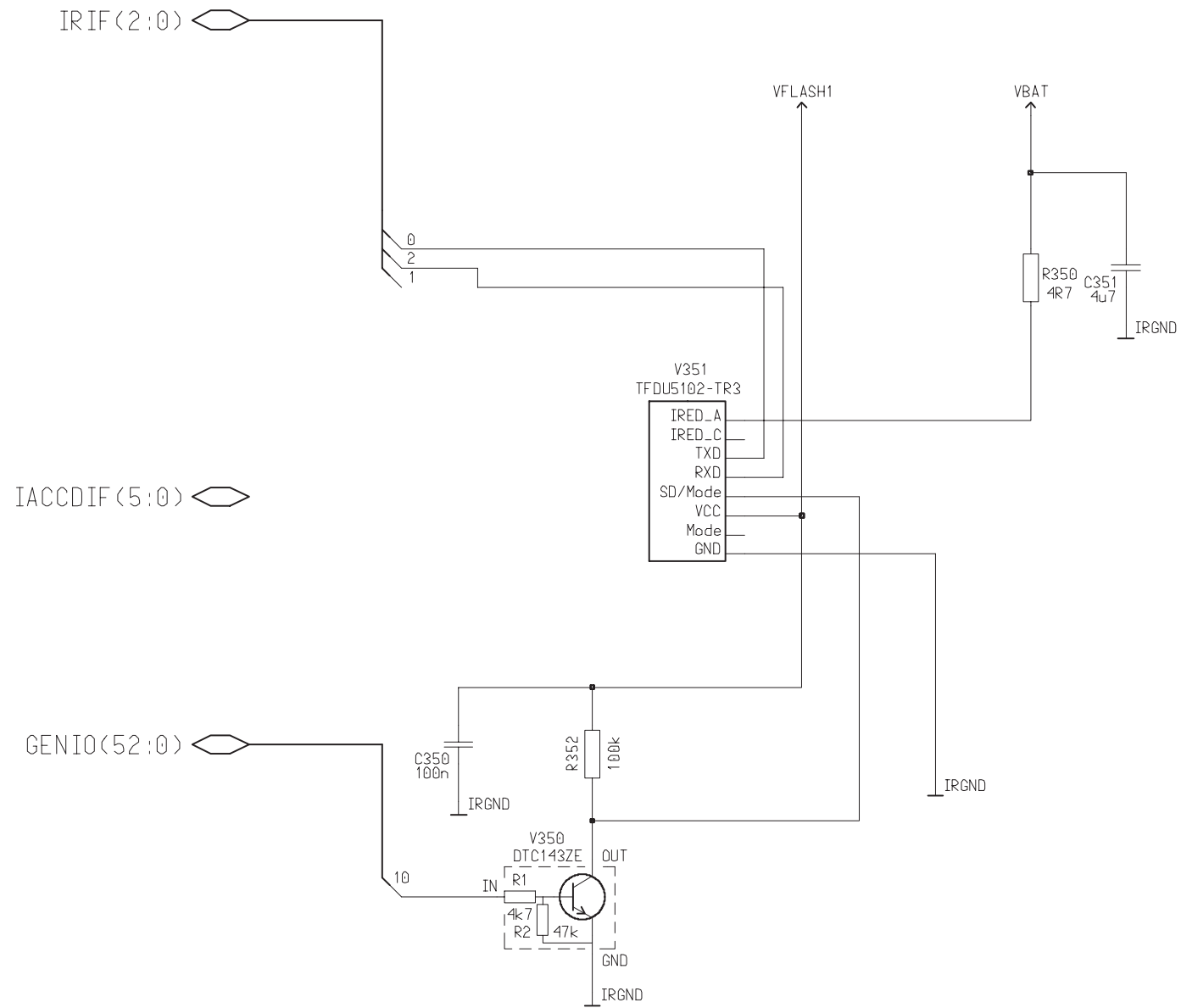

FM Radio (Version 1.3 Edit 104) for layout version 15

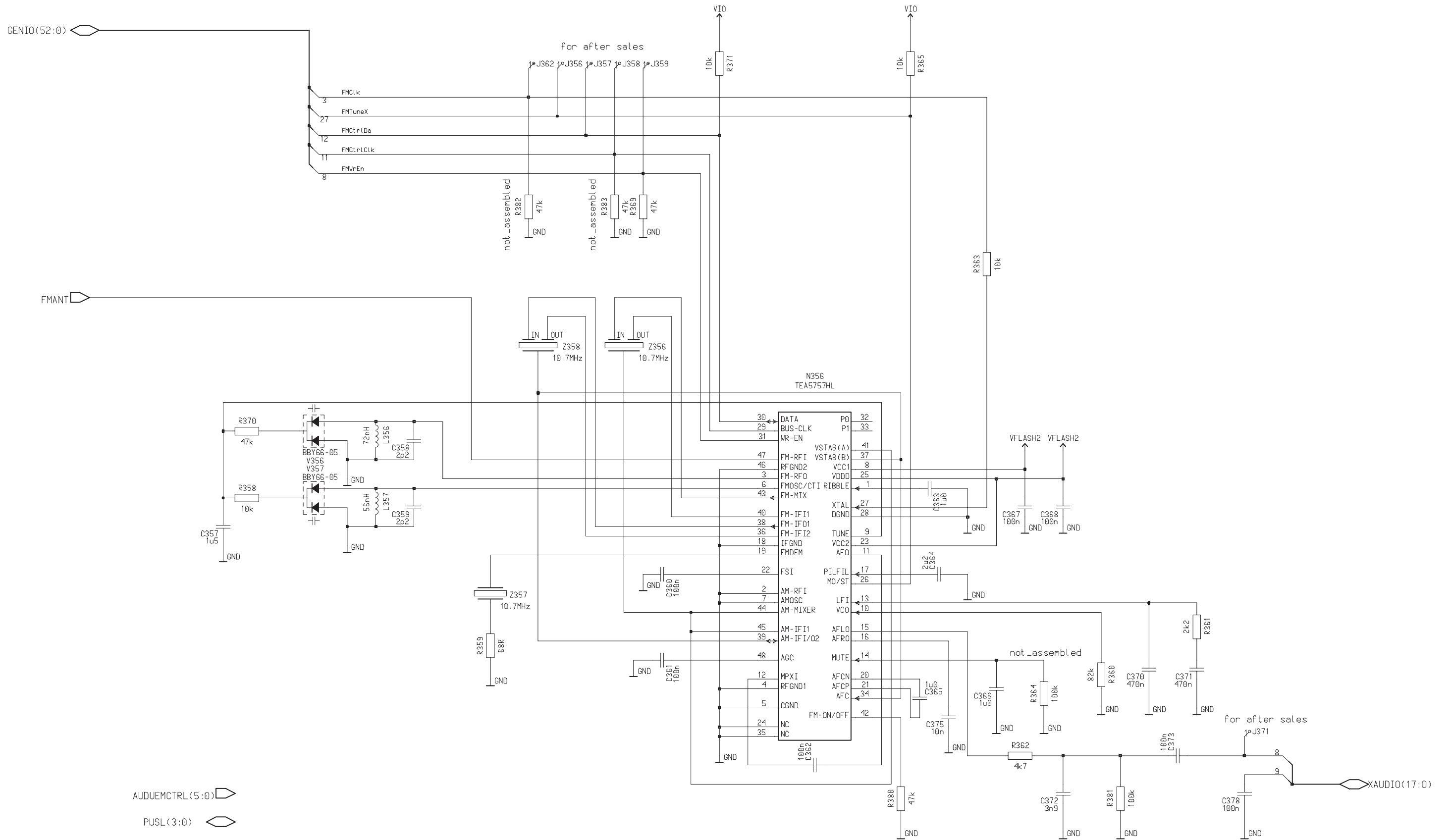

SIM Reader (Version 4.0.1 Edit 49) for layout version 15

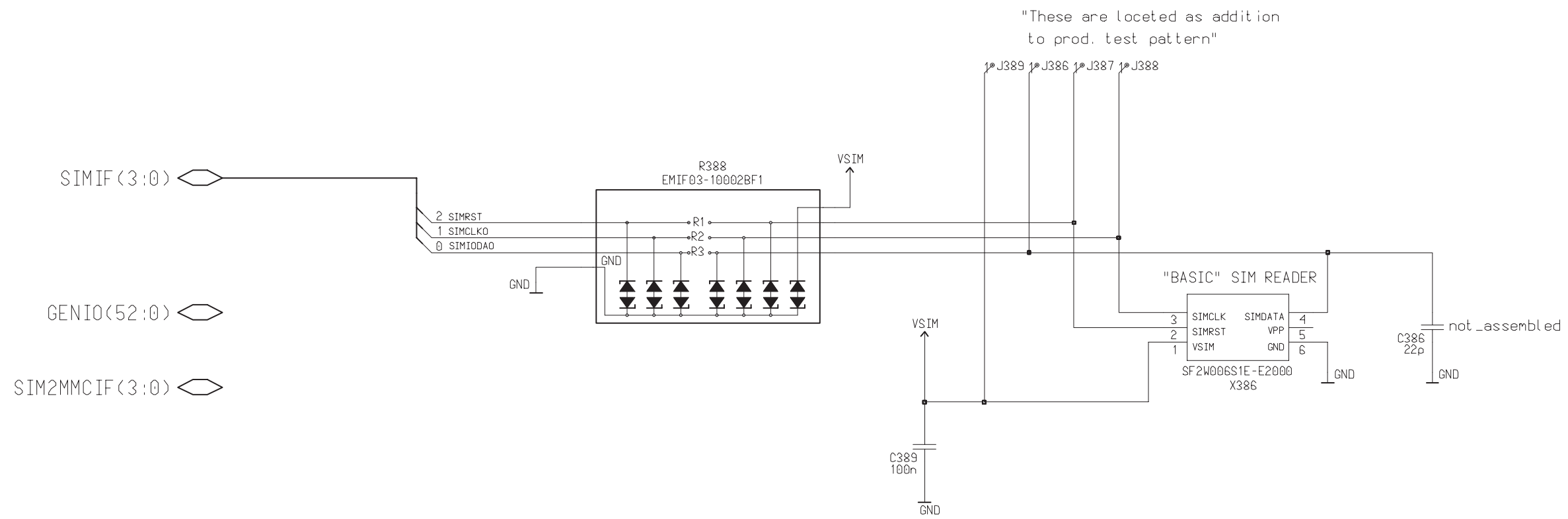

UPP and decoupling capacitors (Version 2.0 Edit 89) for layout version 15

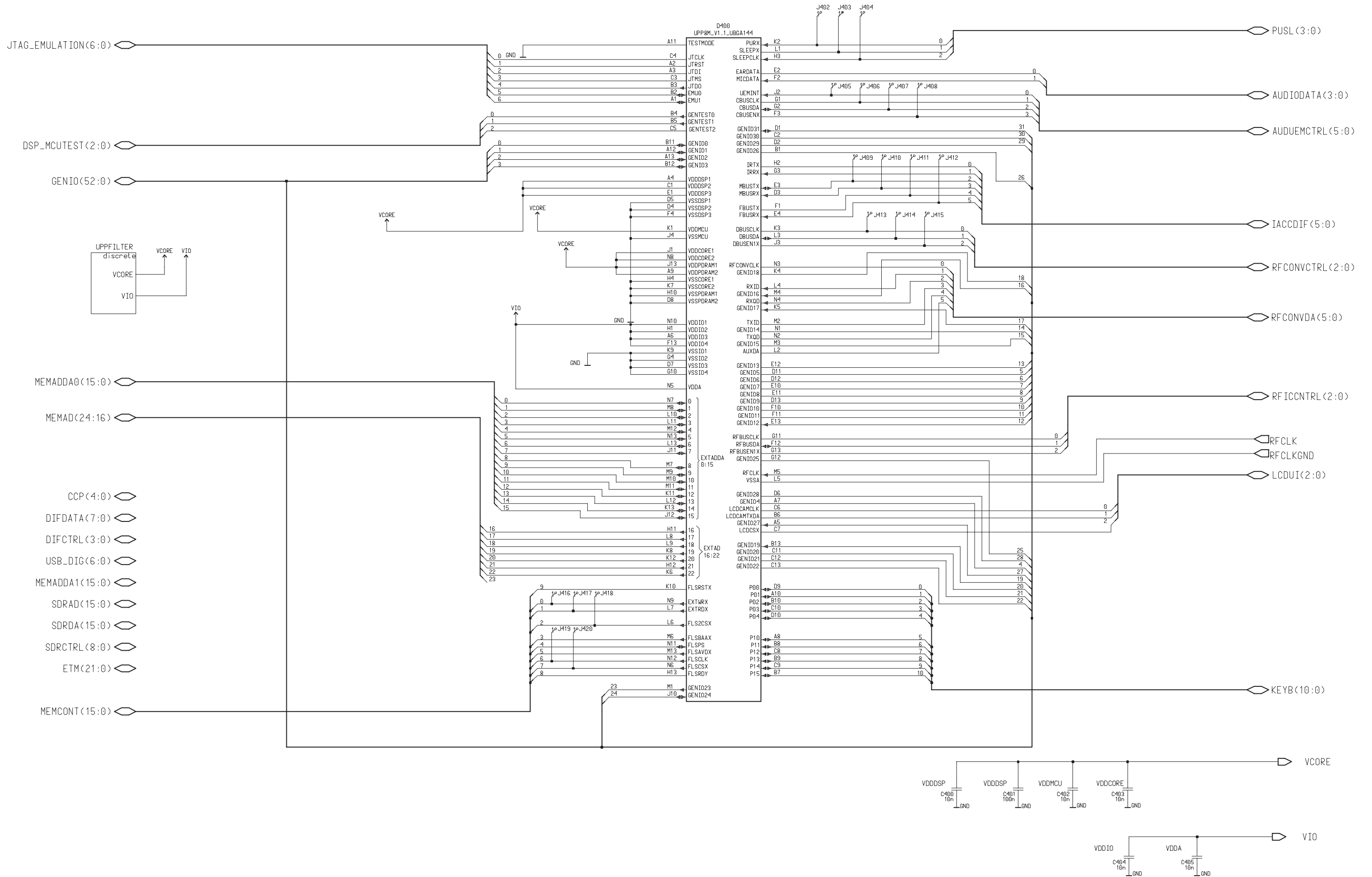

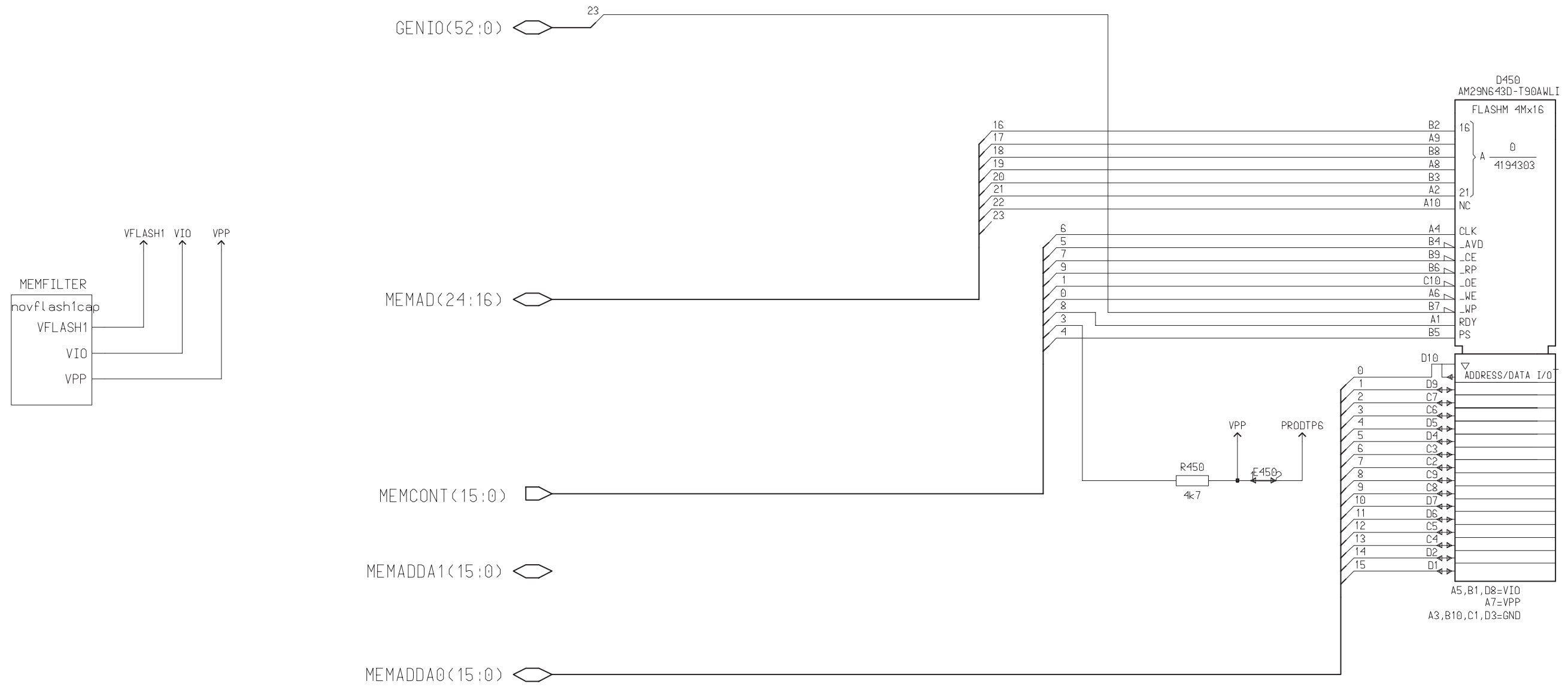

Testpoints of LA5 – Top (Version 15)

Testpoints of LA5 – Bottom (Version 15)

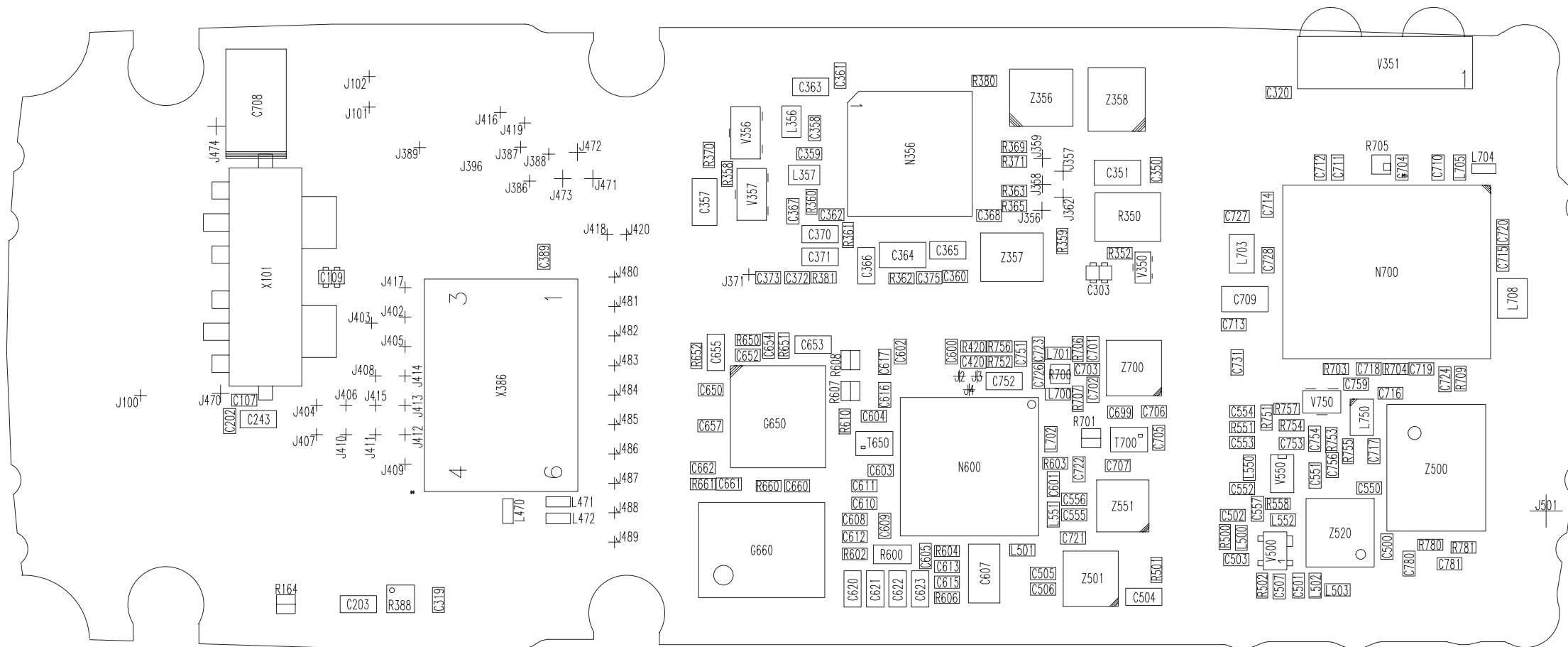

UI Board – LK5 for version 11

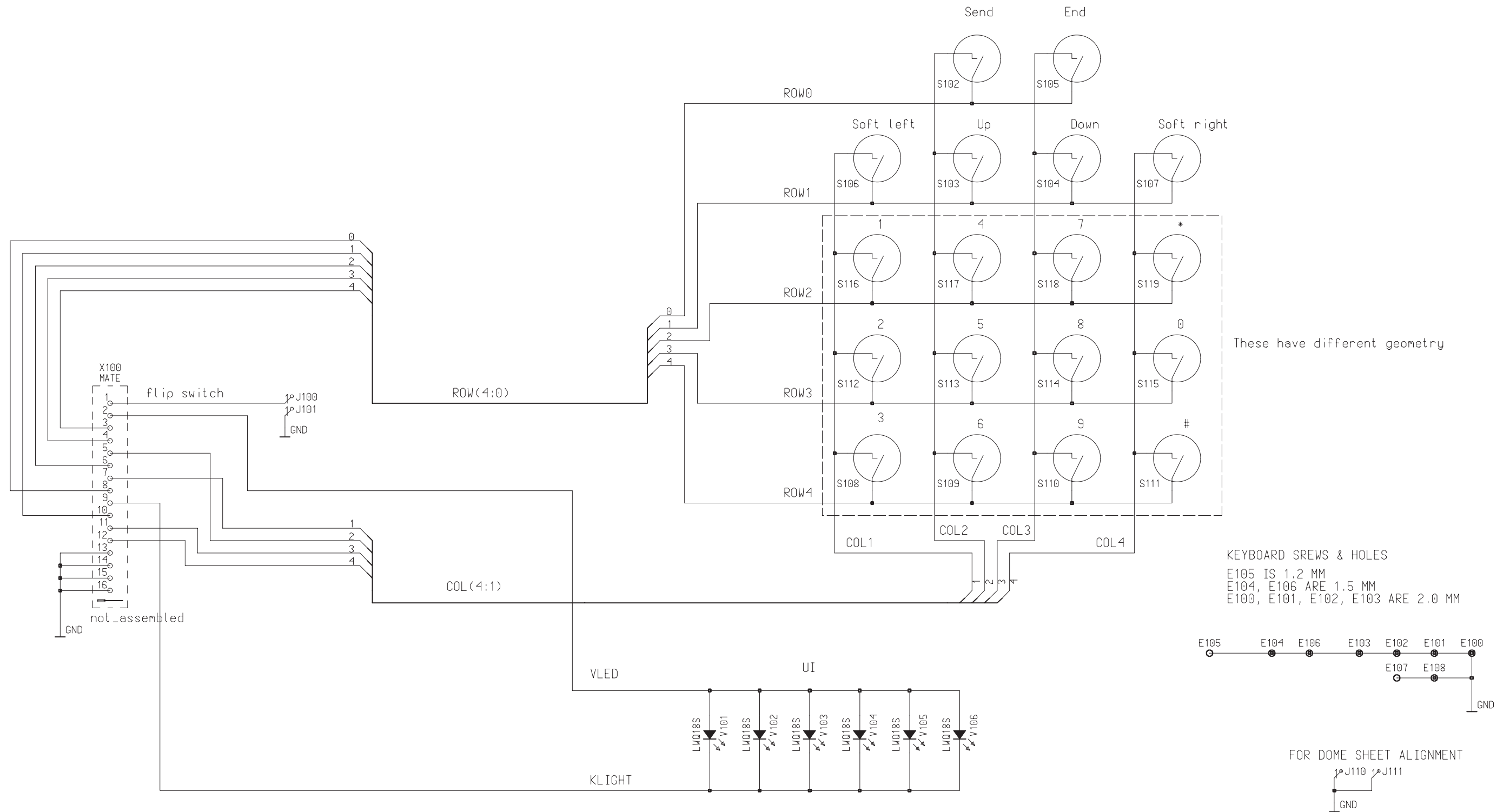

Layout Diagram – LK5 for version 11

